



NMT PLUS 25/60-180

979523853

NMT PLUS / Electronically regulated circulating pump
 Heating/cooling, Klimatizacija

GENERAL

Product number	979523853		
Product name	NMT PLUS 25/60-180		
Seal type		Energy efficiency index	0.17
Net weight	2.39 kg		
Head max. (H max)	5.76 m	H min	0.0 m
Flow max. (Q max)	3.31 m³/h	Q min	0.0 m³/h
	38 %		
Noise	≤43 dB(A)		

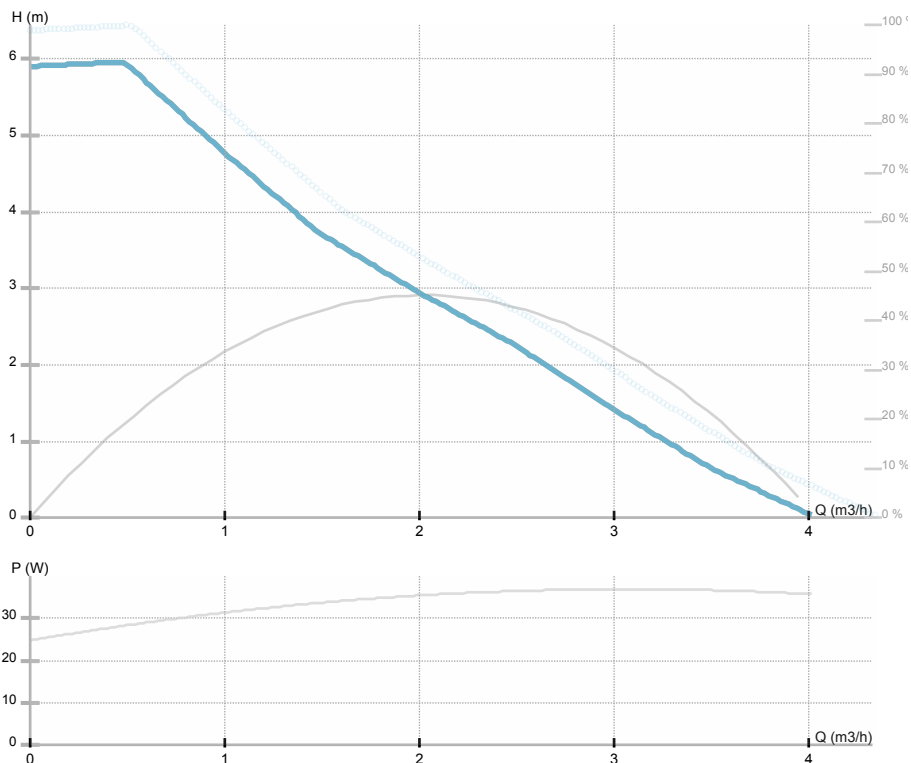

ELECTRICAL DATA

Supply voltage	1~230 V
Mains frequency	50 Hz
Power input max.	36 W
Speed max.	4100 rpm
Insulation class	F (155 °C)
Current max.	0.32 A
Protection class	IP44
Thermal protection	
Frame size	
Motor IE class	

INSTALLATION

Pumped liquid	water VDI 2035, glycol 40%
Liquid temperature	-10.0 ÷ 110.0 °C
Ambient temp.range	40 °C
Port-to-port length	180 mm
Pipe connection	25
Pressure rating	G 1 ½
Connection	G 1 ½
Max operating pressure	1.0 MPa

MATERIAL

Bearing	ceramics
Impeller	Noryl 1630V
Hydraulics	gray cast iron
Shaft	ceramics

NMT PLUS 25/60-180

979523853

NMT PLUS / Electronically regulated circulating pump
Heating/cooling, Klimatizacija





NMT PLUS 25/60-180

979523853

NMT PLUS / Electronically regulated circulating pump

Heating/cooling, Klimatizacija

Dimension drawing

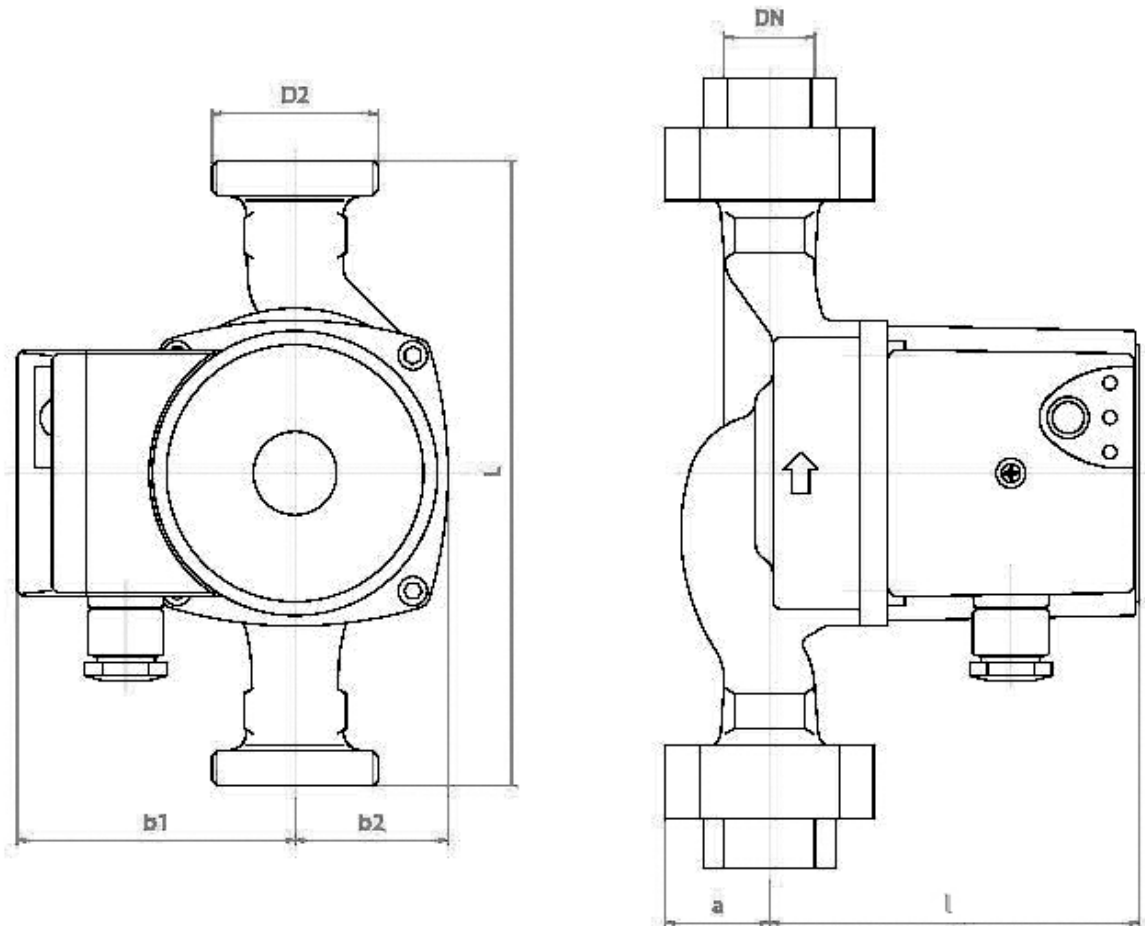

L=180 DN=25 b1=80 b2=48 l=108 a=32 D2=6/4



NMT PLUS 25/60-180

979523853

NMT PLUS / Electronically regulated circulating pump
Heating/cooling, Klimatizacija

Electrical wiring

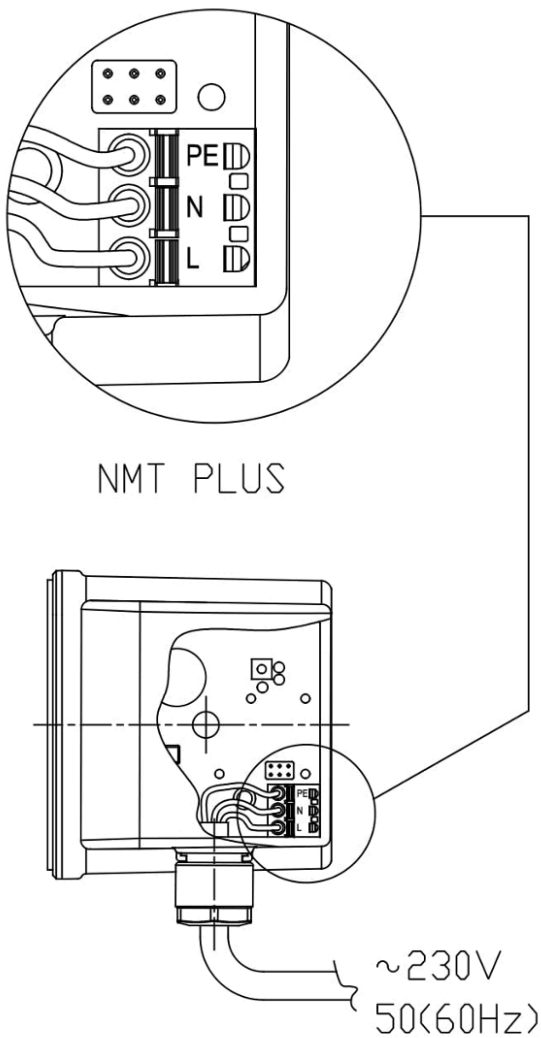



NMT PLUS 25/60-180

979523853

NMT PLUS / Electronically regulated circulating pump

Heating/cooling, Klimatizacija

NMT PLUS 25/60-180 is high-efficiency pump with three-stage regulation for heating systems, air conditioning installations and other circulation systems (circulation is ensured by New Motor Technology - NMT), with screwed connection and integrated electronic power control. The built-in electronics measures the converted pressure and flow values and thus automatically adjusts the duty point according to the set operating mode.

Main features:

- high performance permanent magnet electronically commutated motor (ECM)
- proportional-pressure operating mode
- constant speed operating mode
- built-in electric protection
- easy installation and quiet operation
- automatic air venting function

For normal operation of the pump, it is necessary to use a working medium consisting of clean water or a mixture of clean water and glycol in accordance with current water quality standards for heating systems, for example the German standard VDI 2035. If the glycol content in the working medium exceeds 20%, it is recommended to check the pump parameters Temperature range at an ambient temperature of +25 °C: +2...+110 °C, at ambient temperature +40 °C: +2...+95 °C.

Operating point:

- Flow: 0 m³/h
- Head: 0 m

Pressure and flow tolerances according to ISO 9906-2015.

Electrical data:

- Voltage: 1~230 V
- Maximum current: 0.32 A

Installation data:

- DN: 25
- Installation length: 180 mm
- Net weight: 2.39 kg

The pump is available with threaded (PN10) connection. The hydraulic pump housing is made of gray cast iron, protected by a cathaphoresis coating, which makes the pump more resistant to the environment. The rotor can is made of one piece without welding, the rotor cladding is made of AISI 316 stainless steel, the pump shaft is made of . The impeller is made of synthetic material reinforced with glass fiber PES GF30. The bearings are made of ceramics.