

AMS (deb<200l/mn) Stainless steel centrifugal pump



Application

- Suitable for domestic use, overpressure of pipe, watering of gardens, fish farming, industry and mines, air conditioning systems, etc ...

Pompe

- Stainless steel pump body AISI 304
- AISI 304 stainless steel shaft
- Maximum liquid temperature: +85°C
- Altitude of use: up to 1000 m

Moteur

- Integrated thermal protection for single-phase motors
- Insulation class: F
- Protection class: IPX4
- Maximum ambient temperature: +40°C

Identification codes

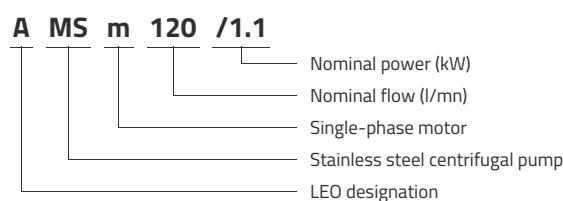

Technical data

MODEL	kW	Q (m³/h)									
		0	1.8	2.4	3.6	4.8	6	7.2	8.4	9.6	
		Q (l/min)									
		0	30	40	60	80	100	120	140	160	
AMSm70/0.37	0.37	20.9	19	18.1	15.7	12.1					
AMS70/0.37	0.37	20.9	19	18.1	15.7	12.1					
AMSm70/0.55	0.55	29.5	27.3	26.3	23.4	19.1					
AMS70/0.55	0.55	29.5	27.3	26.3	23.4	19.1					
AMSm70/0.75	0.75	30.4	28.5	27.8	26	23					
AMS70/0.75	0.75	30.4	28.5	27.8	26	23					
AMSm120/0.55	0.55	20.2			17.9	16.6	15.1	13.3	11.2	8.7	
AMS120/0.55	0.55	20.2			17.9	16.6	15.1	13.3	11.2	8.7	
AMSm120/1.1	1.1	30.2			26.7	25.1	23.3	21.2	19	16.4	
AMS120/1.1	1.1	30.2			26.7	25.1	23.3	21.2	19	16.4	

Dimensions

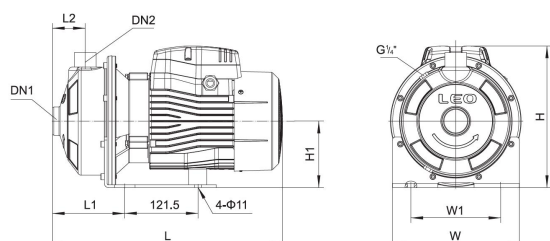

MODEL	DN1	DN2	L	W	H	L1	L2	W1	H1
AMSm70/0.37	1¼	1	332	210	224	119	55	149	110
AMS70/0.37	1¼	1	332	210	224	119	55	149	110
AMSm70/0.55	1¼	1	332	210	224	119	55	149	110
AMS70/0.55	1¼	1	332	210	224	119	55	149	110
AMSm70/0.75	1¼	1	381	210	224	119	55	149	110
AMS70/0.75	1¼	1	381	210	224	119	55	149	110
AMSm120/0.55	1¼	1	332	210	224	119	55	149	110
AMS120/0.55	1¼	1	332	210	224	119	55	149	110
AMSm120/1.1	1¼	1	381	210	224	119	55	149	110
AMS120/1.1	1¼	1	381	210	224	119	55	149	110

Hydraulic performance

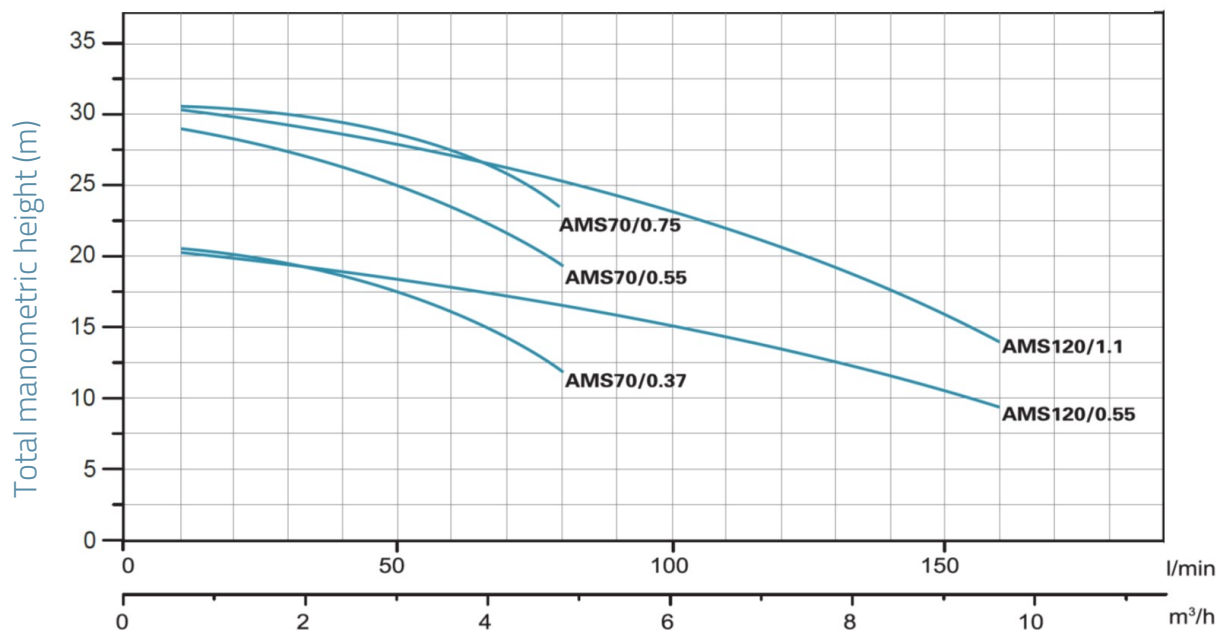

Exploded view

No.	Type	Materials
1	Base	steel
2	Pump body	AISI 304 stainless steel
3	Diffuser	AISI 304 stainless steel
4	Impeller	AISI 304 stainless steel
5	O-ring	nitrile rubber (NBR)
6	Pump bottom	AISI 304 stainless steel
7	Lantern	cast aluminum ZL102
8	Mechanical seal	silicone / carbon
9	Bearing	
10	Rotor	
11	Stator	
12	Fan	polypropylene
13	Rear cover	cast aluminum ZL102
14	Fan cover	polypropylene
15	Electric box cover	ABS

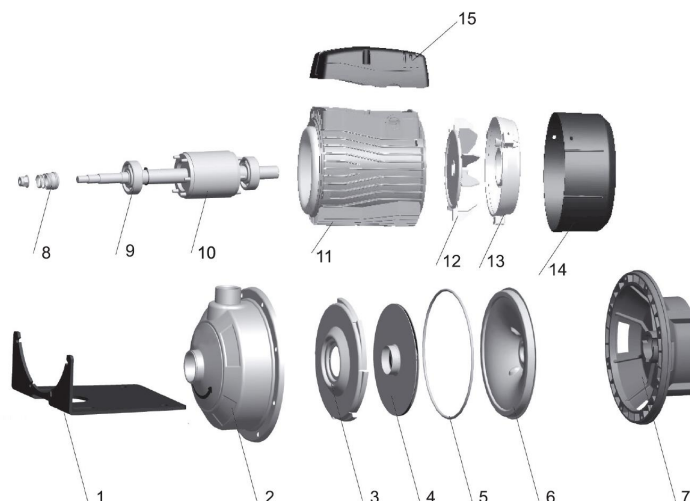

Packaging

MODEL	Weight (kg)	Length L (mm)	Width W (mm)	Height H (mm)
AMSm70/0.37	10	380	240	270
AMS70/0.37	10	380	240	270
AMSm70/0.55	11	380	240	270
AMS70/0.55	11	380	240	270
AMSm70/0.75	14	410	240	270
AMS70/0.75	14	410	240	270
AMSm120/0.55	11	380	240	270
AMS120/0.55	11	380	240	270
AMSm120/1.1	15	410	240	270
AMS120/1.1	15	410	240	270

